

ENGINEERING DATA

THERMALLY CONDUCTIVE, PATENTED ALUMINUM CORE

The cross-flow heat recovery core transfers heat between the two airstreams. It is easily removed for cleaning or service.

MOTORS AND BLOWERS

Each airstream has an independent motorized impeller with multiple fan speed operations.

FILTERS

Washable air filters in exhaust and supply airstreams.

MOUNTING THE HRV

Threaded inserts at corners of the cabinet designed to accept the "S" hooks and hanging straps supplied with the unit.

DEFROST

Recirculating damper defrost system.

CASE

20 gauge prepainted galvanized steel for superior corrosion resistance, insulated to prevent exterior condensation. Drain connections: Two 1/2 in (12 mm) OD. Balancing ports are located on unit.

INSTALLER SELECTABLE HIGH SPEED SETTINGS

Adjustable DIP switches are located on the circuit board, HI3 is the factory setting. Refer to the Installation manual for the adjustment instructions.

ELECTRONICS

The optional controls can be wall mounted in a central location of the home. 3 wire 20 gauge (min.) 100 ft length (max.).

CONTROL OPTIONS

99-DXPL02 Lifebreath Digital Control

- 5 speed operation on each mode
- Humidity control through adjustable Dehumidistat
- 5 user selectable operational modes: Continuous Ventilation, Continuous Recirculation, 20 ON/40 OFF, 10 ON/50 OFF, 20 ON/40 Recirculation
- 20/40/60 min. High speed override button
- Compatible with 99-DET02 Wireless Timers
- 3 wire connection

99-BC02 Lifebreath Ventilation Control

- 2 speed fan setting (Low/High)
- Humidity control through adjustable Dehumidistat
- Compatible with 99-DET02 Wireless Timers
- 3 wire connection

TIMER OPTIONS

99-DET01 Lifebreath 20/40/60 Minute Timer - Initiates High speed Ventilation for 20, 40 or 60 minutes. 3 wire connection.

99-DET02 Lifebreath WIRELESS 20/40/60 Minute Timer - Initiates High speed Ventilation for 20, 40 or 60 minutes. Wirelessly connects to main control for ease of installation. 40' approximate range.

99-RX02 Lifebreath WIRELESS Repeater - Used to extend range of 99-DET02 Wireless Timers. Plugs into 120V power outlet. Wirelessly connects to main control and 99-DET02. Install at halfway point between timer and main wall control if timer is out of range.

ACCESSORY OPTIONS

99-163 Duct Heater w/Electronic SCR Thermostat - 1 kW, 6 in (152 mm)

99-185 Weatherhoods - Two 5 in (127 mm)

99-190 Dual Hood - One 6 in (152 mm) opening for supply and exhaust.

DIMENSIONS RNC5-TPD **WEIGHT** 51 lbs (23 kg) **SHIPPING WEIGHT** 54 lbs (25 kg)

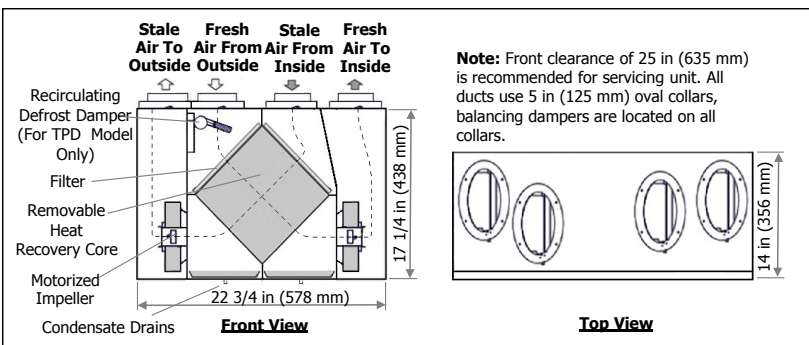

Performance (HVI certified)		
Net supply airflow in cfm (L/s) against external static pressure		
External Static Pressure	Airflow	
@ 0.1 in (25 Pa)	169 cfm (80 L/s)	
@ 0.2 in (50 Pa)	156 cfm (73 L/s)	
@ 0.3 in (75 Pa)	149 cfm (70 L/s)	
@ 0.4 in (100 Pa)	136 cfm (64 L/s)	
@ 0.5 in (125 Pa)	126 cfm (59 L/s)	
@ 0.6 in (150 Pa)	116 cfm (54 L/s)	
@ 0.7 in (175 Pa)	103 cfm (48 L/s)	
@ 0.8 in (200 Pa)	89 cfm (42 L/s)	
@ 0.9 in (225 Pa)	77 cfm (36 L/s)	
@ 1.0 in (250 Pa)	58 cfm (27 L/s)	
Max. Temperature Recovery	78%	
Sensible Effectiveness @ 66 cfm (31 L/s)	32°F (0°C)	74%
Sensible Efficiency @ 66 cfm (31 L/s)	32°F (0°C)	61%
Sensible Efficiency @ 76 cfm (36 L/s)	-13°F (-25°C)	63%
VAC @ 60Hz	120	
Watts / Low speed.	69	
Watts / High speed	147	
Amp rating	1.7	

Sensible Efficiency: Thermal Effectiveness: Based on temperature differential between the 2 airstreams
Efficiency: Takes into account all power inputs

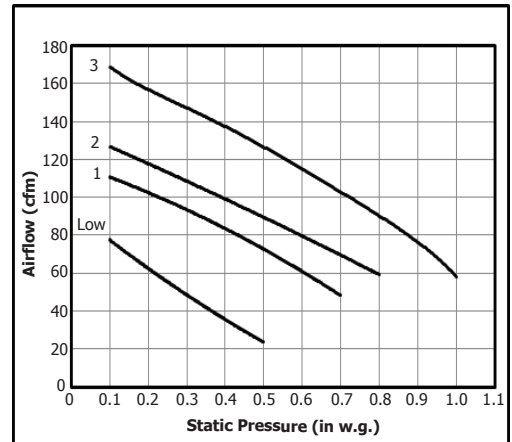

WARRANTY

Units carry a lifetime warranty on the HRV core and a 5 year replacement parts warranty.

All units conform to CSA and UL standards
 NOTE: All specifications are subject to change without notice.

Date: _____ Contractor: _____
 Tag: _____ Qty: _____ Supplier: _____
 Project: _____ Quote #: _____
 Engineer: _____ Submitted By: _____